

# Large Capacity Solar Dryer for rural Ecosystem

**“Every Watt is Precious”**

Prof.Dr.S.D.Suryawanshi

(Energy Auditor EA-1826)

Professor and Head Department of  
Mechanical Engineering,

SSVPS' BSD College of Engineering, Dhule

sanjeevsuryawanshi@gmail.com

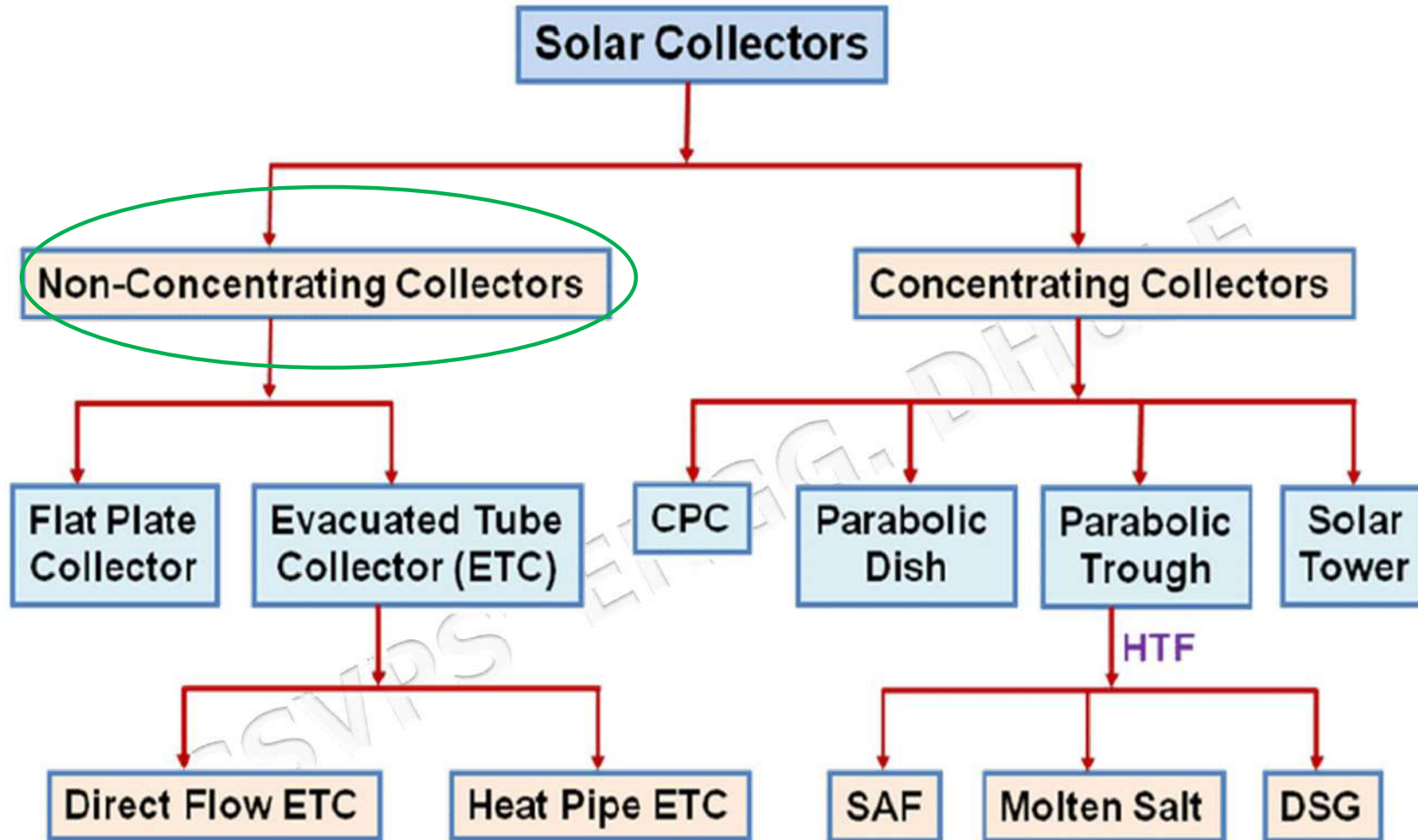

CPC – Compound Parabolic Concentrator; SAF – Synthetic aromatic fluid; DSG – Direct steam generation;

# A Solar Collector, Principle

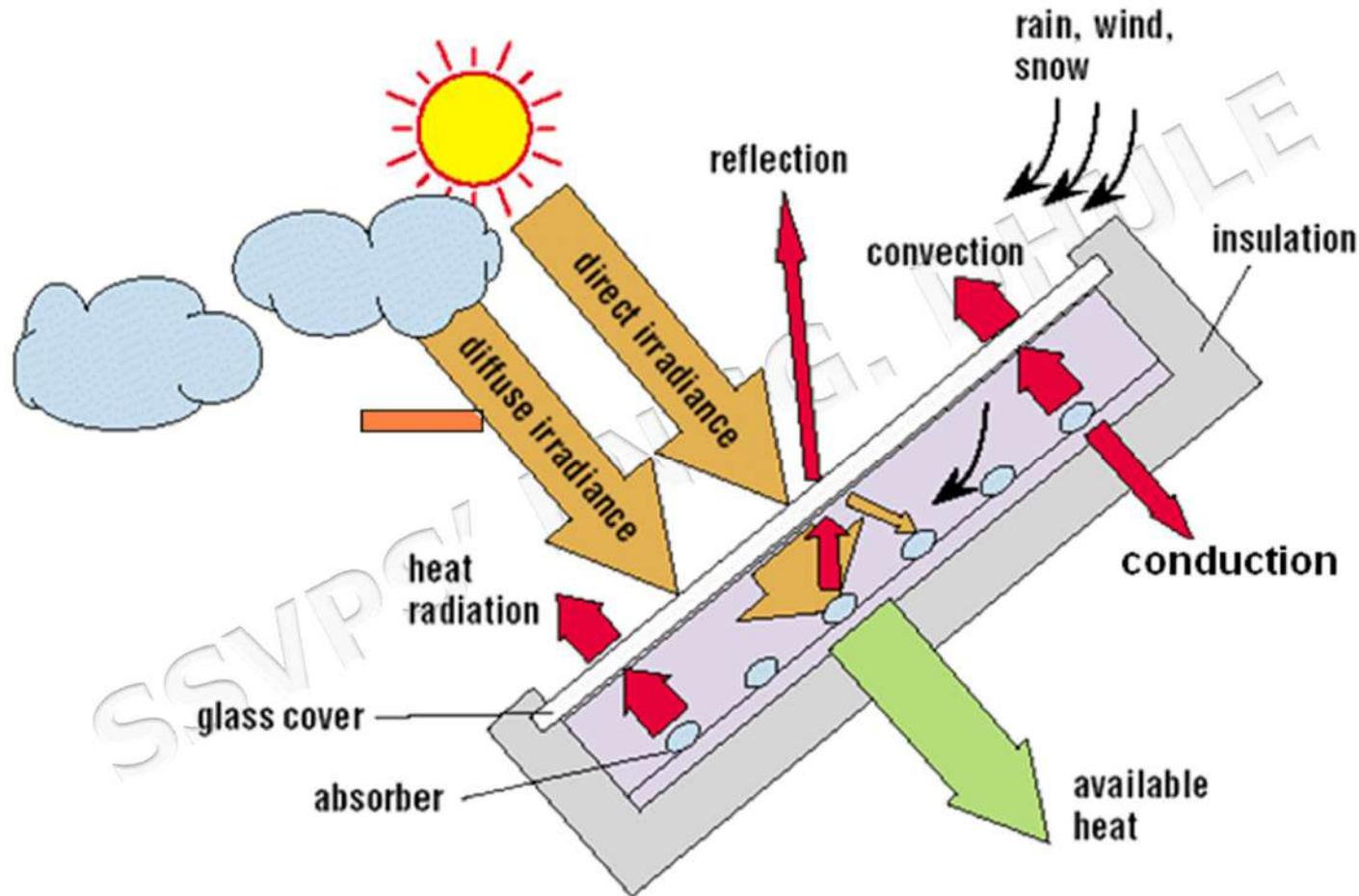

# Problem statement (Solar dryers)

- Solar dryer cum disinfectant for domestic needs
  - **Challenges**
    - Size
    - Cost
    - Handy
- Solar dryer for Industrial needs
  - **Challenges**
    - Capacity (1 Kg,100 kg,500 kg and 1000kg)
    - Uniform drying
    - 24X7 Operation
    - Energy bill

# What are the Conventional Methods to Preserve Agricultural Produce?

# Conventional Method, *Vigilance*



5/13/2026

Every watt is presious

# Technology Available in the Market



5/13/2026

Every watt is precious

# Problem

- Food stuff like legumes and pulses, spices ,dry fruits, etc. are very commonly and easily infested by **weevils**, **pantry beetles**, **flour bugs**, **ghuns (in Hindi)**, **grain borer**, etc.



# Present Solution **Pest** Control

Dusting(Boric powder)



Fumigation  
(Methyl Bromide)

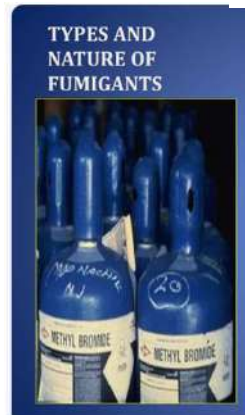

Pallets (Aluminium Phosphide)



# Effects

- Most people are unaware of the fact that they have accidentally ingested the larva, eggs or a nasty little weevil, as these are unavoidable.
- Infestation of these agents causes adverse effects on our health.
- **Reduced shelf life**
- Destruction of other foodstuffs
- Food poisoning
- **Nausea, Vomiting, Indigestion**
- Reduces germination rate

# The Problem .....

- Use of chemicals on grain causes dreadful consequences on human health, as the residues of these chemicals are left even after proper management.
- These chemicals also harm **the environment**.
- Conventional solar driers are usually made for commercial purposes and not for domestic applications.
- Costly, foodstuffs exposed to UV rays affect *aroma, flavour, colour and nutritional value*.

# Purpose

- To save *food from spoiling before or during storage*
- Paste control without chemicals
- Preservation of food without the use of any conventional energy sources (Heat or Electrical Energy)
- Provide **a handy, healthy and ecological gadget** to prevent food spoilage working on solar energy

# Comparison of Solar Drying

Chemical Treatment	Open Air Drying	Conventional Solar Dryer
<ul style="list-style-type: none"> <li>● Pest control by using chemicals is not foolproof.</li> <li>● Most of the chemicals are <b>carcinogenic</b>.</li> <li>● Residues of chemicals in food stuffs has <b>disastrous effect on health</b> .</li> </ul>	<ul style="list-style-type: none"> <li>● Requires constant vigilance.</li> <li>● Contamination by bird droppings.</li> <li>● UV exposure leads to loss of <b>nutritional value, taste and aroma</b>.</li> <li>● Slow ,time consuming requires large space.</li> <li>● Unsuitable in urban use.</li> </ul>	<ul style="list-style-type: none"> <li>● Partial exposure to UV rays affects color, aroma, nutritional value.</li> <li>● Requires attention .</li> <li>● Periodic cleaning and maintenance is required.</li> </ul>

# Comparison of solar drying

• Chemical Treatment	• Open Air Drying	• Conventional Solar Dryer
<ul style="list-style-type: none"> <li>• The chemicals, even after they are washed away, still remain in the ecology affecting other components of it like water, soil which will ultimately affect humans.</li> </ul>	<ul style="list-style-type: none"> <li>• Unsuitable in monsoons as moisture, rain, wind can damage the agricultural produce.</li> <li>• Pollution by dust, insects, fungus, microbial contamination etc.</li> <li>• Not intense enough to kill all pests.</li> </ul>	<ul style="list-style-type: none"> <li>• High capital investment.</li> <li>• Requires more floor space</li> </ul>

# Comparison of solar dryers in the market and the Hemispherical solar dryer

OpenAir Drying	Conventional Solar Dryer (Cabinet, Tunnel dryer etc.)	Hemispherical Solar Dryer
<ul style="list-style-type: none"> <li>• UV exposure leads to loss of <i>nutritional</i> value, taste and aroma.</li> <li>• Requires constant vigilance.</li> <li>• Contamination by bird droppings and fungal growth.</li> <li>• Slow, time consuming requires large space.</li> </ul>	<ul style="list-style-type: none"> <li>• Exposure to UV rays affects color, aroma, taste and nutritional value.</li> <li>• Requires attention .</li> <li>• Periodic cleaning and maintenance is required.</li> <li>• Air change is difficult due no of locations of air release</li> <li>• Automation is difficult due difficult operation of air change</li> <li>• Volume to surface area ration is less for cabinet or tunnel solar dryer</li> <li>• morning and evening solar radiations can not be utilized</li> </ul>	<ul style="list-style-type: none"> <li>• No exposure to <i>UV rays</i></li> <li>• Retains color, aroma, <i>nutritional value</i>.</li> <li>• Air change is easy and controllable as only a single location of air release at the top.</li> <li>• Automation is possible with close control on temperature and humidity saves time and improves the quality of the product.</li> <li>• <i>Volume to surface area ratio is highest</i> for the hemispherical solar dryer, which gives maximum loading capacity for a given size.</li> <li>• <i>Utilises morning and evening solar radiation</i>, providing more sunshine hours.</li> </ul>

## Colour Comparison and rehydration Capacity of produce after drying





Drying in our dryer  
neem leaves



Open sun drying  
neem leaves

**SOLAR DRYER CUM DISINFECTION SYSTEM (test setup for 1 Kg )**  
11 samples of pulses,rava, maida, groundnut etc.



Sample testing  
Difference after three months



Maida

(Pitcher) Mataka

Every watt is presious

## Test results Total Viable Count (TVC)

<b>Sample no.</b>	<b>Sample name</b>	<b>Status</b>	<b>TVC/gram</b>
<b>1</b>	<b>Groundnut</b>	<b>Pre-Treatment</b>	<b>110000</b>
		<b>Post treatment</b>	<b>40000</b>
<b>2</b>	<b>Coriander seeds</b>	<b>Pre-Treatment</b>	<b>160000</b>
		<b>Post treatment</b>	<b>10000</b>
<b>3</b>	<b>Yellow petite lentils</b>	<b>Pre-Treatment</b>	<b>110000</b>
		<b>Post treatment</b>	<b>40000</b>

# Time Vs Temperature



Date: 05-10-2024

Time Vs Temperature

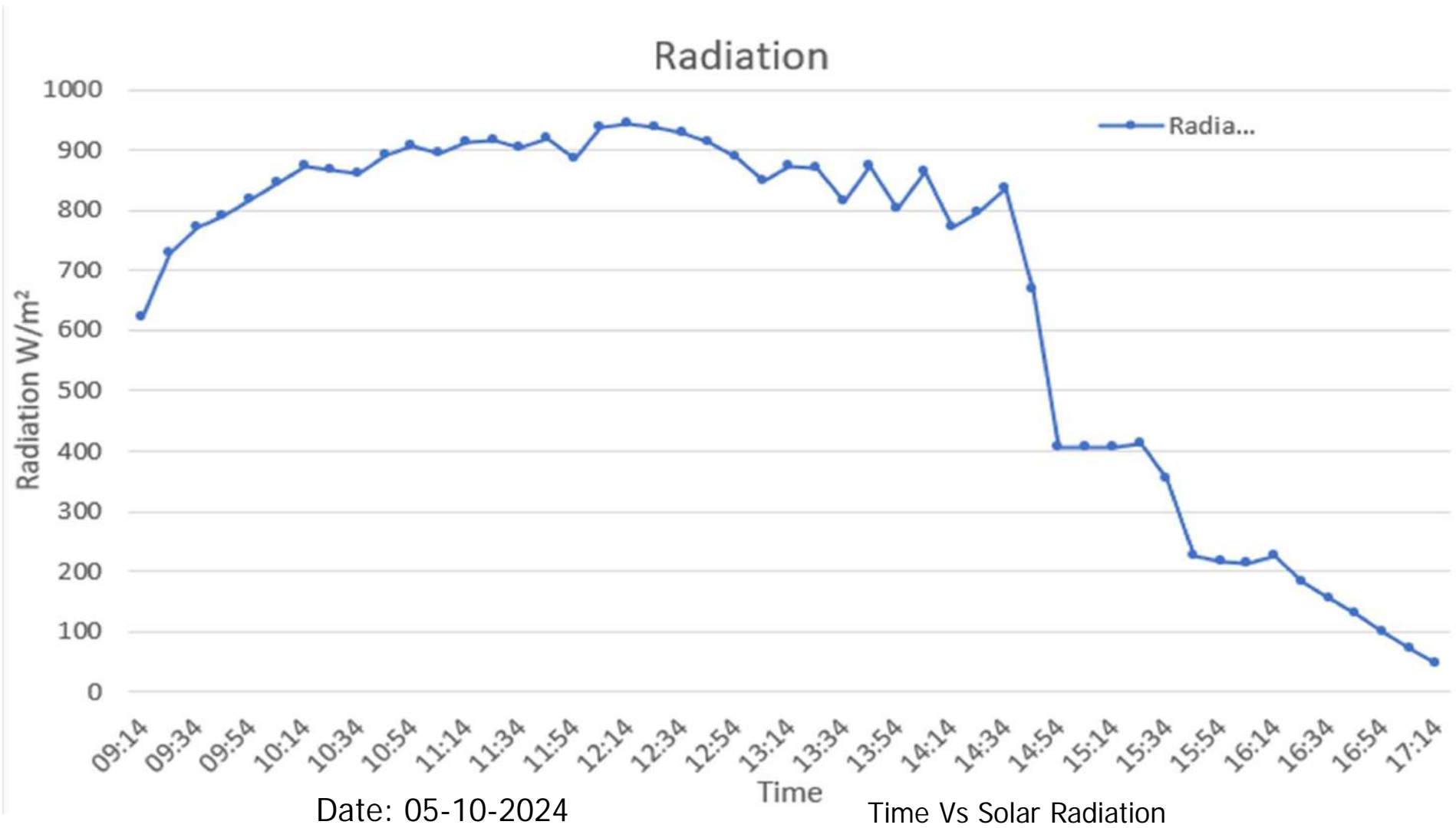

## Market-ready product



5/13/2026



5/13/2026

Every watt is presious



5/13/2026

Every watt is presious

25



5/13/2026

Every watt is presious

26

## SOLAR DRYER CUM DISINFECTION SYSTEM (Modular Version) Automation

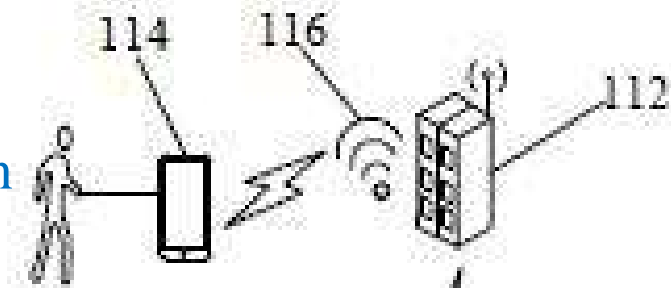

## SOLAR DRYER CUM DISINFECTION SYSTEM (Modular Version)

- 114 User devise
- 112 Controller
- 116 Communication Media

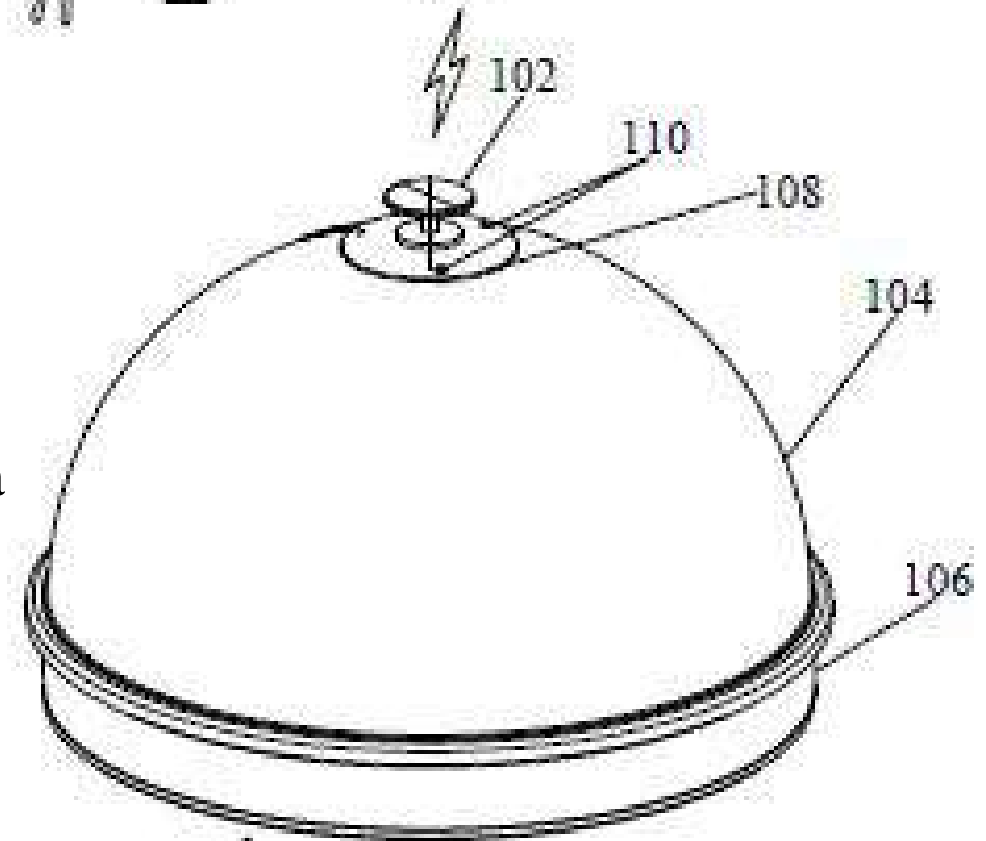

# SOLAR DRYER CUM DISINFECTION SYSTEM (Modular Version)

- 1004 Air change knob
- 1024 Air vent valve

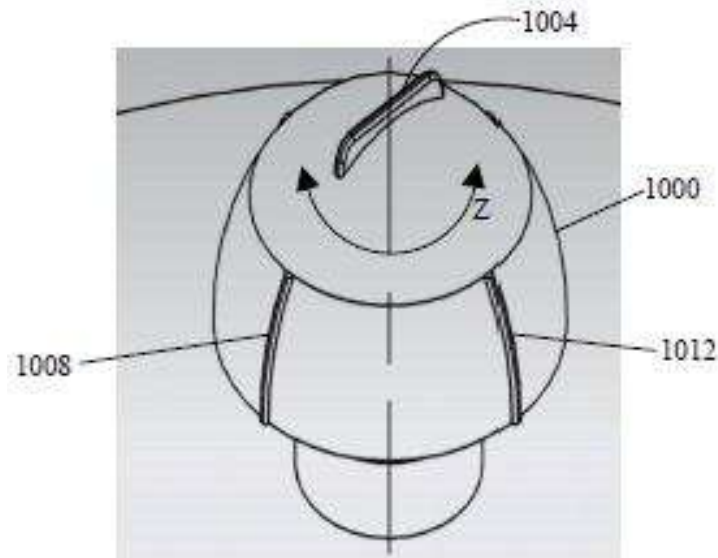

Details of Air Change Knob

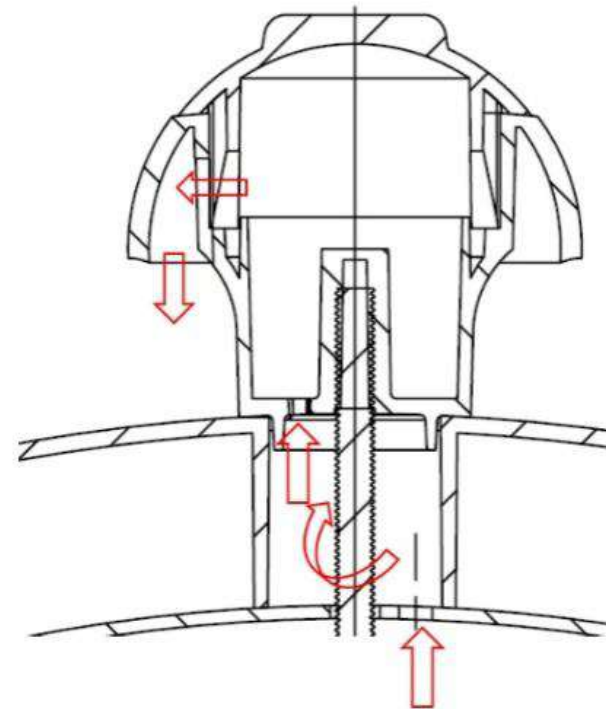

Solar Dryer Cum Disinfector System, modular version  
(1.5 m diameter) 100 Kg loading



## Performance of Industrial Solar dryer cum disinfector 100 kg Capacity

Neem leaves drying



Retention of colour of  
Neem leaves after drying



Decolourisation of Neem  
leaves in open air drying

## Industrial Solar dryer cum disinfector 100 kg



Assembly



Bamboo frame and fish net Trays

SS 304 frame and SS mesh Trays

# SOLAR DRYER CUM DISINFECTION SYSTEM (Industrial version 3 meter diameter) 500 Kg loading capacity

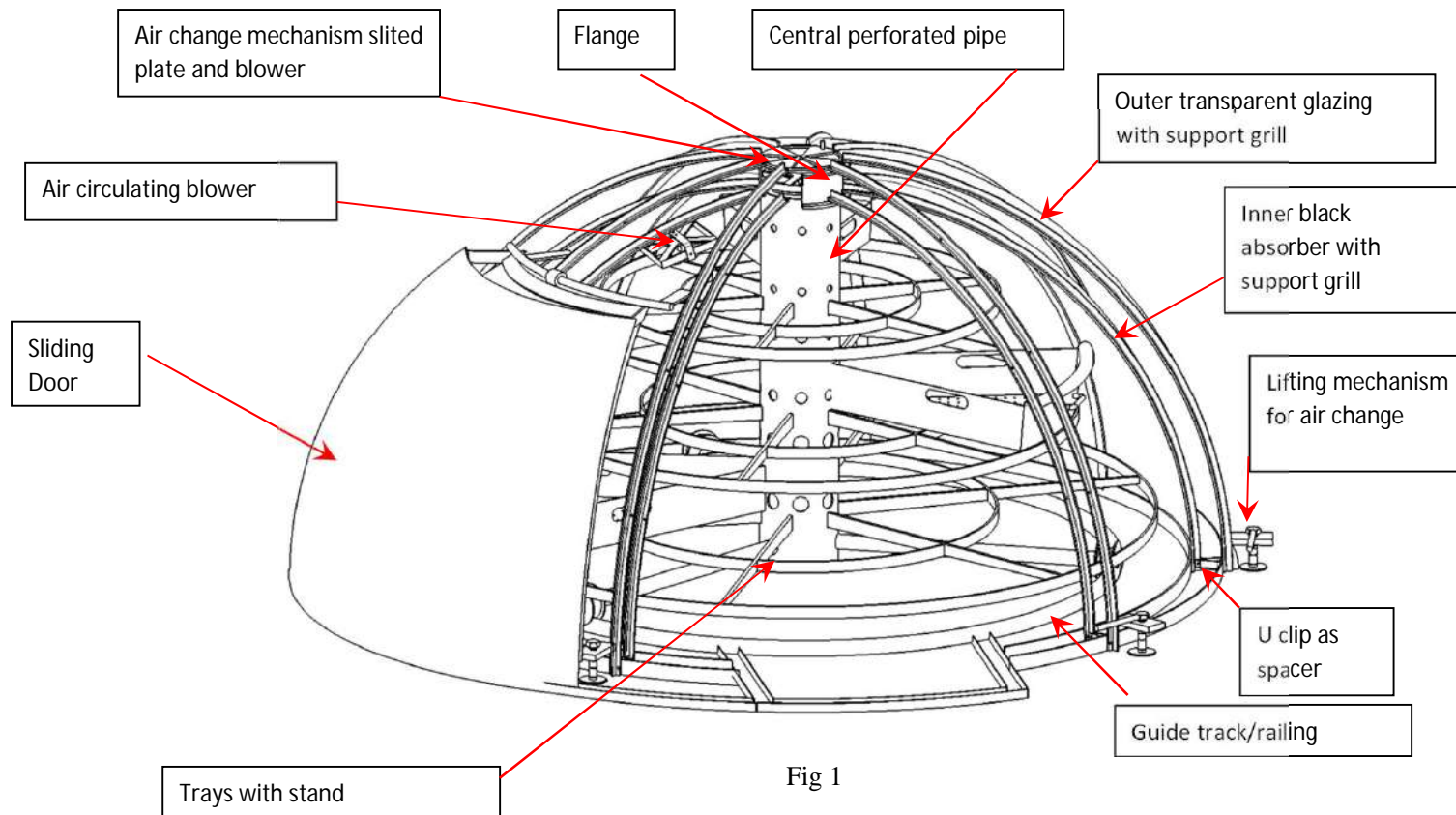

SOLAR  
DRYER CUM  
DISINFECTI  
ON SYSTEM  
(Industrial  
version  
specifically  
for agro  
industry )  
Exploded  
view

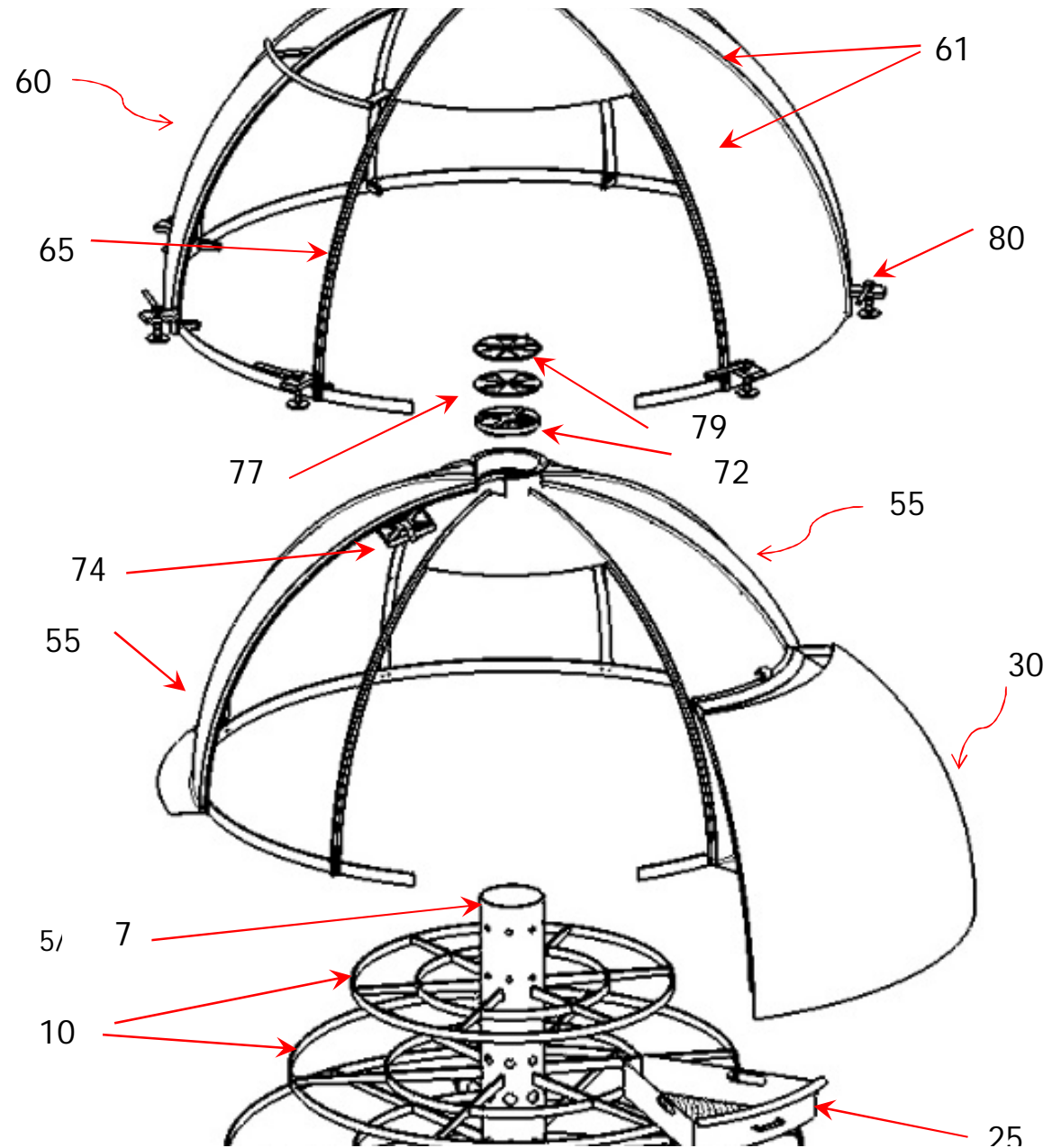





SOLAR DRYER CUM DISINFECTION SYSTEM (Industrial version  
3 meter diameter) 500 Kg loading capacity



## SOLAR DRYER CUM DISINFECTION SYSTEM 500 Kg loading capacity ,trays with grapes loaded for resin manufacturing



5/13/2026

Every watt is precious

37

## Solar Dryer Cum Disinfector (500 kg) Drying of grapes to resin



Grapes Loaded (internal details)

Final product Resin

# Comparison with Existing Dryers

Cabinet Dryer



Solar Tunnel Dryer

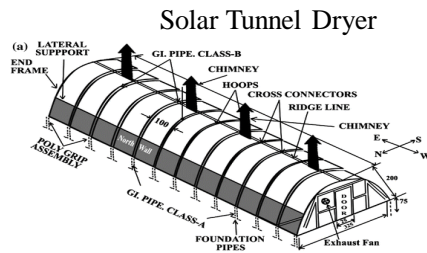

Hemispherical Solar Dryer

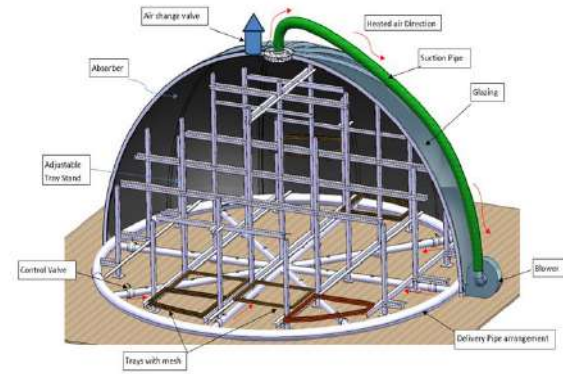

Every watt is precious

## Comparison with Existing Dryers

Sr. No	Characteristics	Cabinet Solar Dryer	Solar Tunnel Dryer	Hemispherical Solar Dryer
1	Air Change Mechanism	Multiple point , Multiple Blowers required	Multiple point , Multiple Blowers required	Single Point, Single Blower required
2	Installation of Air Change Mechanism	Installation on Ridge	Installation on Ridge	Installation on Crest
3	Power & Maintenance of Air Change Mechanism For same capacity	More(140%)	More (130%)	Less(100%)
4	Effectiveness of Air Change	Poor (Dead Zones Created)	Poor (Dead Zones Created)	Good (Proper Air Change throught the Drying Chamber)

6	Geometrical Advantage (Drying Volume in cubic meter for 1 m radius or side of cube )	1	1.57	2.09
7	Insulation	Required	Not Required	Not Required
8	Orientation	Needs due south orientation	Major axis orientation is East-West	No need of due south Orientation
9	Utilization of Solar Radiation	No Morning Evening Solar Radiations Utilized	Morning Evening Solar Radiations Not effectively Utilized	Morning Evening Solar Radiations effectively Utilized
10	Ultra Violet Exposure	Affects Colour, Aroma, Flavour & Nutritional Value	Affects Colour, Aroma, Flavour & Nutritional Value	Retainment of Colour, Aroma, Flavour & Nutritional Value
11	Drying Space Utilization	Poor(70%)	Moderate (80%)	Effective(100%)
12	Disinfection Capability (Temperature Control)	Moderate	Low	High
13	Cost for same capacity	Moderate(150%)	Less(100%)	Moderate(130%)

# Large Capacity Hemispherical Solar Dryer with 24/7 operation

*Patented technology(530948)*

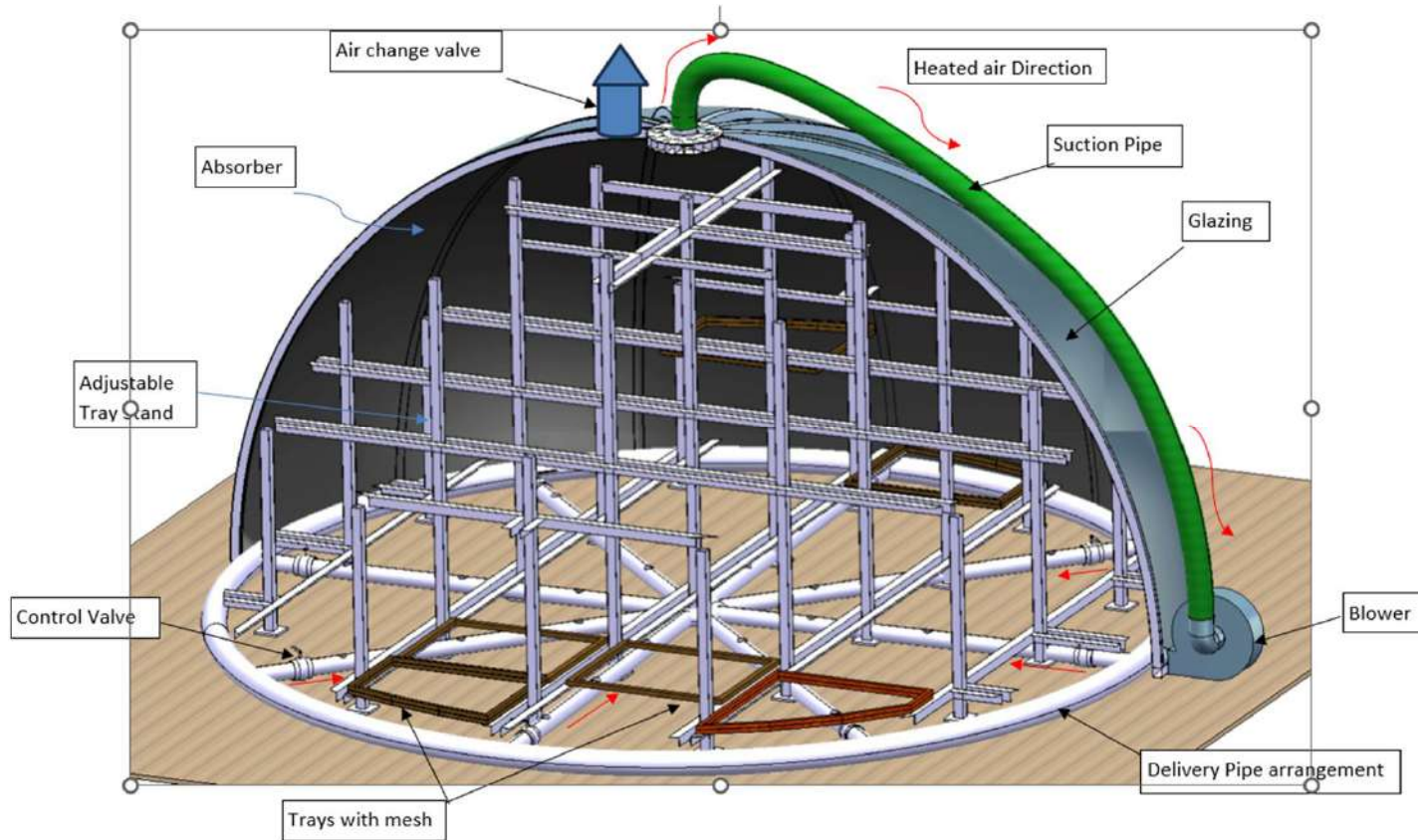

**Visit of Mr Salim Huzefa, Director *La Foundation Dassault Systèmes***



## Large Capacity Hemispherical Solar Dryer with 24/7 operation *Patented technology(530948)*

*Funded by La Foundation Dassault Systèmes with a grant of RS 8.26 Lakhs*

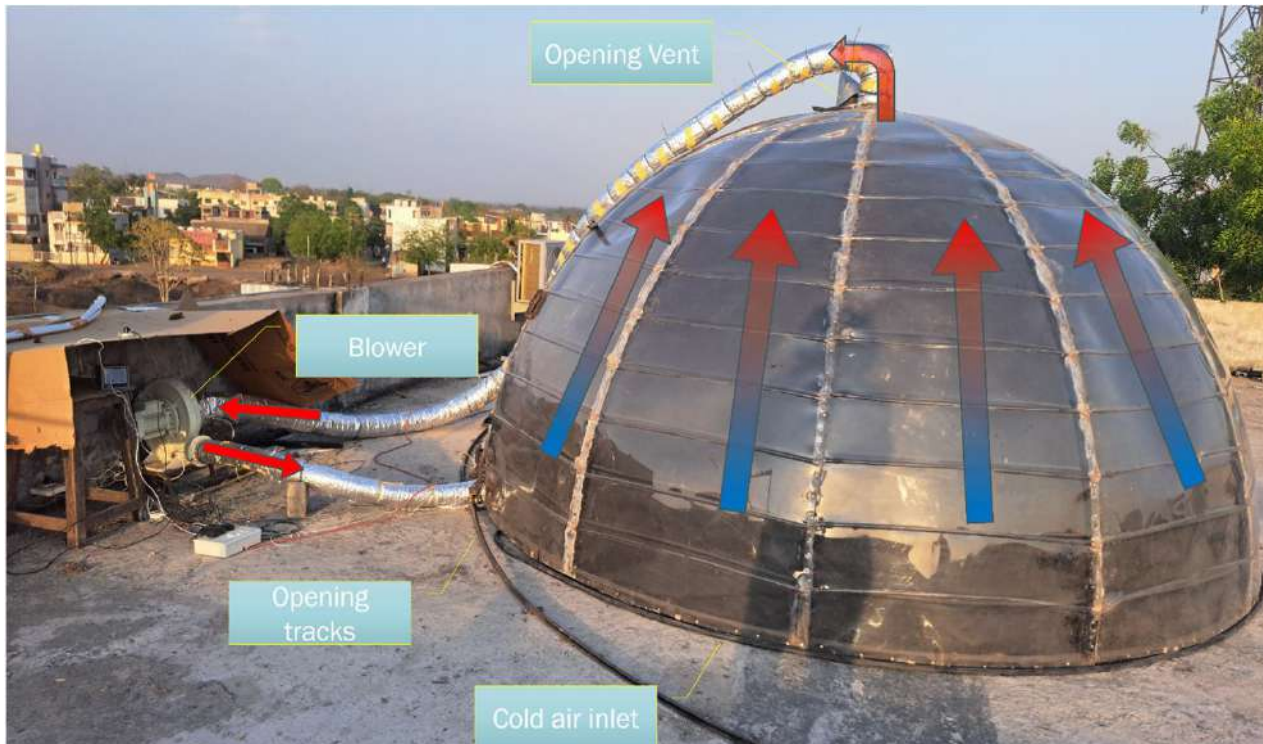

- Size = 4 meters base diameter
- Space required to install = 15 m<sup>2</sup>
- Blower = 1 HP single-phase AC
- Tray area = 80 m<sup>2</sup>
- Tray material = Stainless Steel (SS304)
- Automatic control of temperature as per the requirement throughout the operation
- IOT supports observation and control through the mobile

Loading unloading of Solar Dryer  
Cum Disinfector (1000 kg)

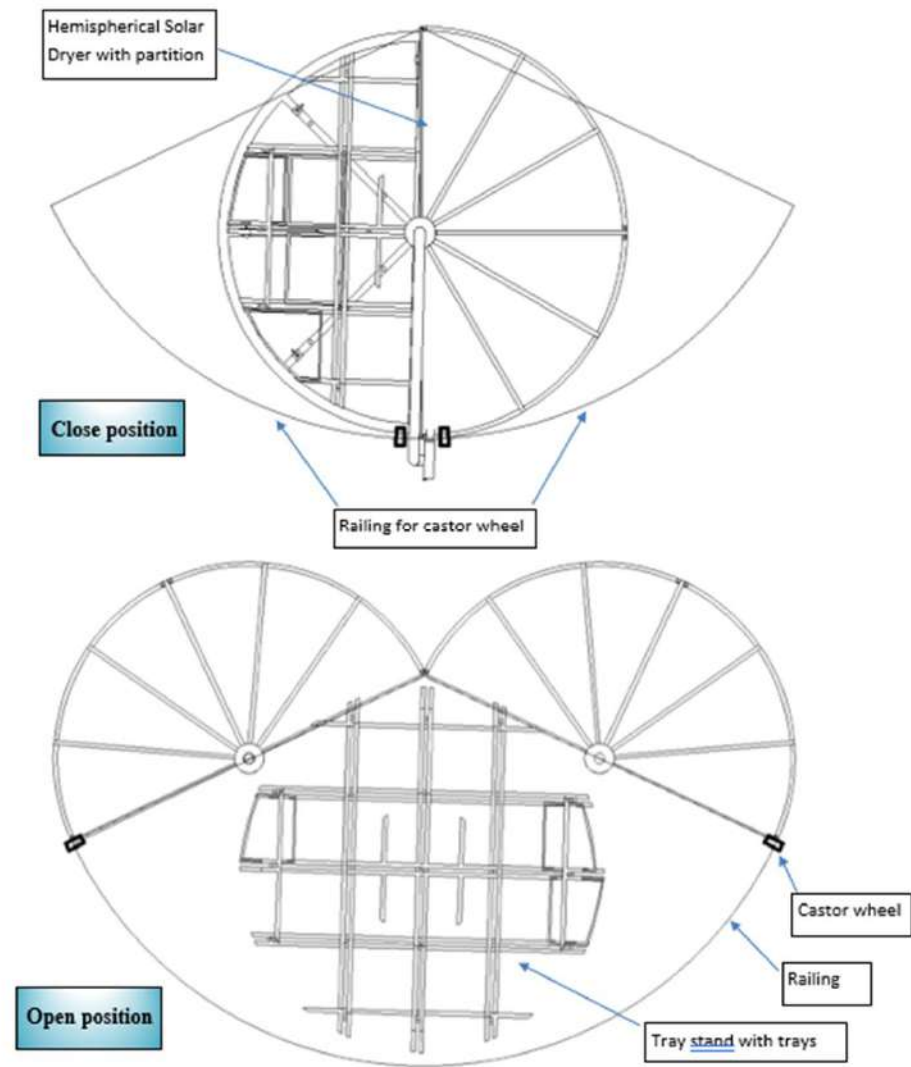

Assembly of Collector of Large Capacity Hemispherical Solar Dryer for Rural Ecosystem (1000 kg) showing Tray Stand

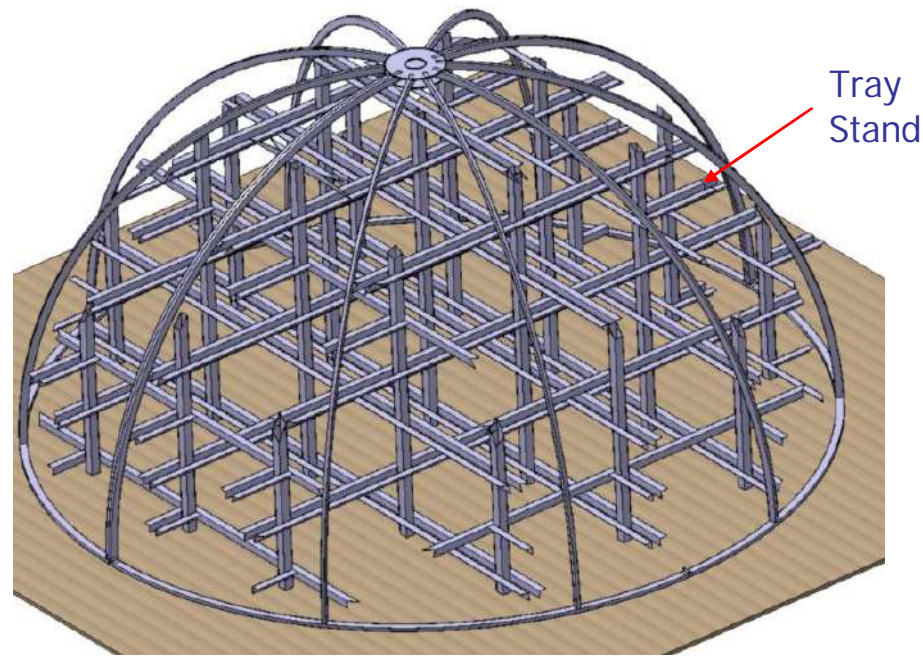

# 24X7 operation tested for (1.5 m diameter) 100 Kg

24X7 operational details

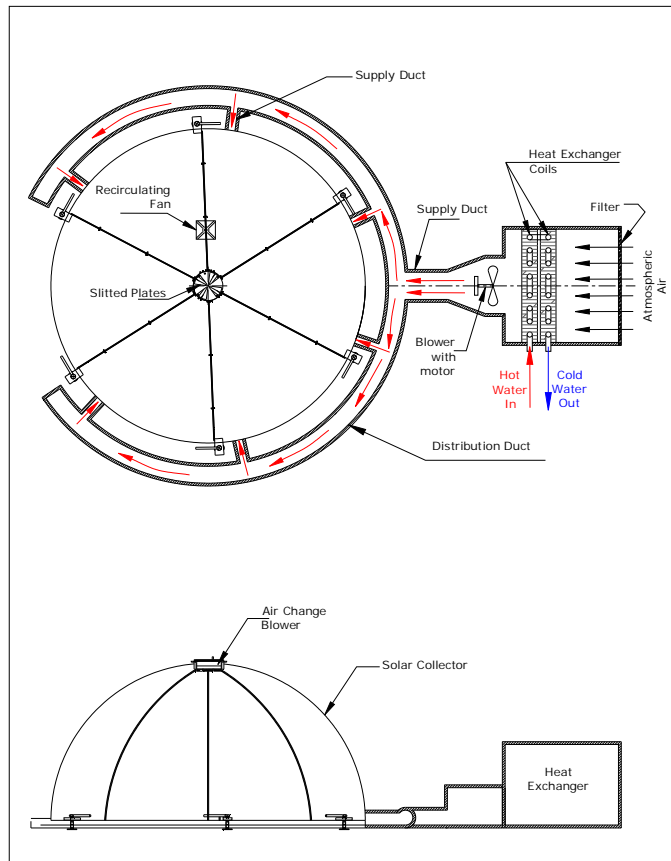

# Non-cattle Feed-Based Biomass Boiler

- A boiler that operates on non-cattle feed biomass as a fuel.
- In the absence of sunshine, the heat energy stored in water is used to heat the air.
- This heated air is supplied to the dryer by using the same blower that is used during the daytime.
- Temperature is controlled by the flow of both hot water and incoming atmospheric air
- Operation is controlled by the controller to maintain the predefined temperature of the air



**Boiler**

# Ginger Processing



Raw Ginger



Loaded Sliced Ginger closeup view



Sliced Ginger



Loaded Sliced Ginger in Dryer

5/13/2026

Every watt is precious

## Final Solar-dried Product



Final product, raisins



Dried Ginger flakes

# Banana Drying



5/13/2026

Every watt is precious

51

# Web Development <https://solardryer.vercel.app/>



SolarDry Solutions

Home

Blog

Our Products

About

Contact Us

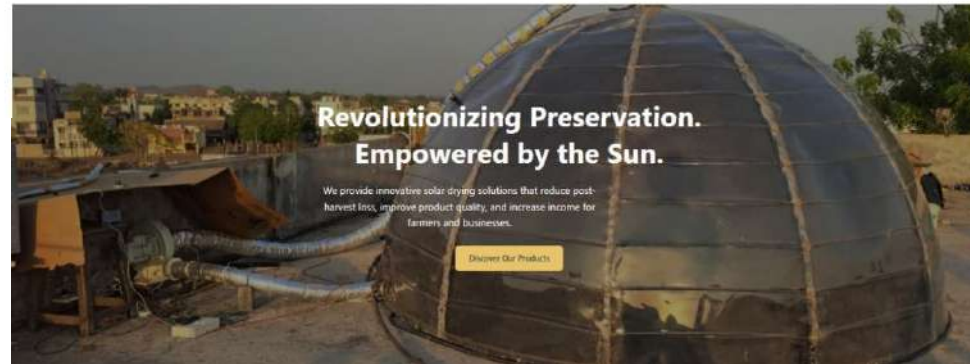

SolarDry Solutions

Home Blog Our Products About Contact Us



Contact us Section

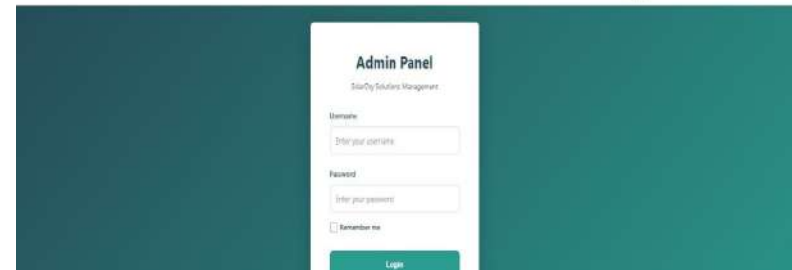

Admin Panel  
(Access is only to  
website  
Administrator)

Access to this page is only given after entering the correct password

## Admin Dashboard

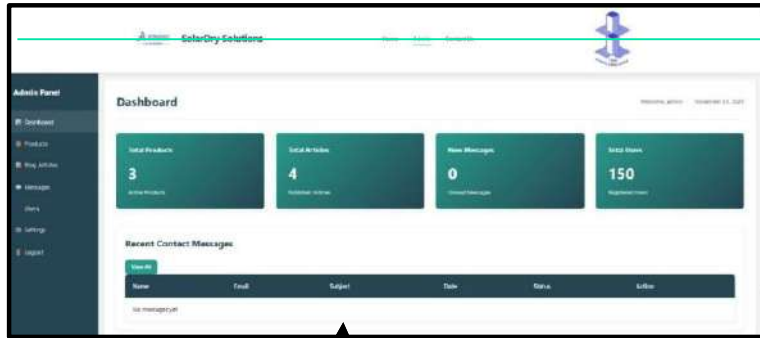

Admin Dashboard



Contact us Message will be view Here

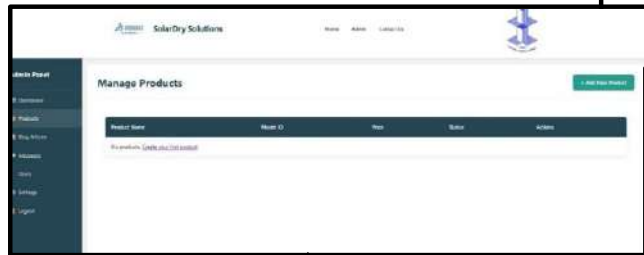

Product Section



Blog Admin Section

# App Development

<https://solardryer.vercel.app/>

*SauryaSetu* is an Android-based blogging app showcasing the complete research work of the Hemispherical Solar Dryer. The app uses Google Firebase to centralise all data, enabling real-time access instead of storing information locally. Users can explore structured research posts categorised into ginger, raisins, curry leaves, and various other solar-dried products. Designed to provide a clean, accessible, and research-focused digital platform.

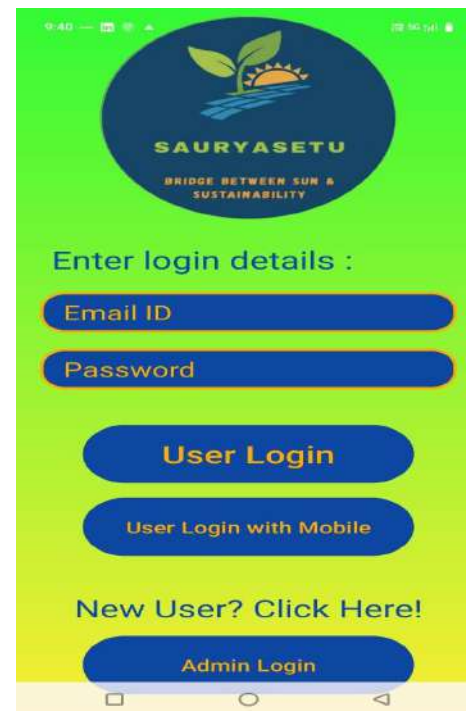
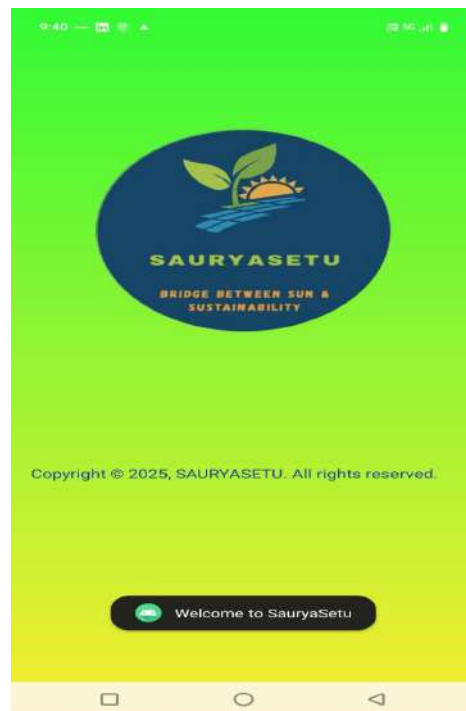

Category-wise blog access: Users can view data such as ginger, raisins, curry leaves, etc, in organised categories. Discussion forum: A built-in forum allows users to ask doubts and engage in academic discussions. Google Firebase to make the system centralised, buttons to visit the website of app, college and department.



# Highlights

Prevents spoilage of product due to rain and wind.

- Reduces time of drying
- Reduces shrinkage, retains rehydration capacity.
- Prevents the contamination from dust, dirt, insects, animals dander and other microbial and fungal growth.
- Presence of 13-16% moisture causes enormous growth the grain pest, reduce it to 10-12% by solar drying increases the shelf life upto 6 months.

## Market comparison

Description	Sheds	Conventional solar dryers	Hemispherical Solar Dryer or Patented Technology
Market Share (household)	Not suitable	Not suitable	Only suitable
Commercial Application	Moderate effective	Moderate effective	Effective
Disinfection	Not effective	Moderate effective	Effective
Process time	Extremely High	High	Moderate
Cost comparison	Low	High	Moderate
Foot print area	Extremely large	Moderate	Moderate
Installation orientation	Not relevant	Required	Universal (Resting on the floor )
Remark			Only system useful for farmers, industrial processing and household applications

*Only system that serves the entire market domain that is farmers, industrial processing, traders and household applications.*

# Project objectives

- To develop trays of stainless steel material for long-term reliable operation in the available large capacity hemispherical solar dryer.
- To find the drying characteristics of bananas and Grapes by experimentation with two drying cycles.
- To find the loading intensity of bananas and grapes per square meter of tray area.
- To find the disinfection capability for linen in a hospital setup.
- To find the disinfection ability of dry agricultural produce like pulses, dry fruits, etc. to improve their shelf life.
- To establish the reliability of experimental results through validation using 3D technology and simulation. CFD simulation is performed with various design parameters, including loading intensity of agricultural produce, air change, and related air flow rate of the blower, as well as temperature and humidity in relation to available solar radiation.

# Awards achievements publications

- Patents
- Grant
- Awards MET HTS
- Publications
- Media

# Grant Approval mail from La Foundation Dassault Systèmes

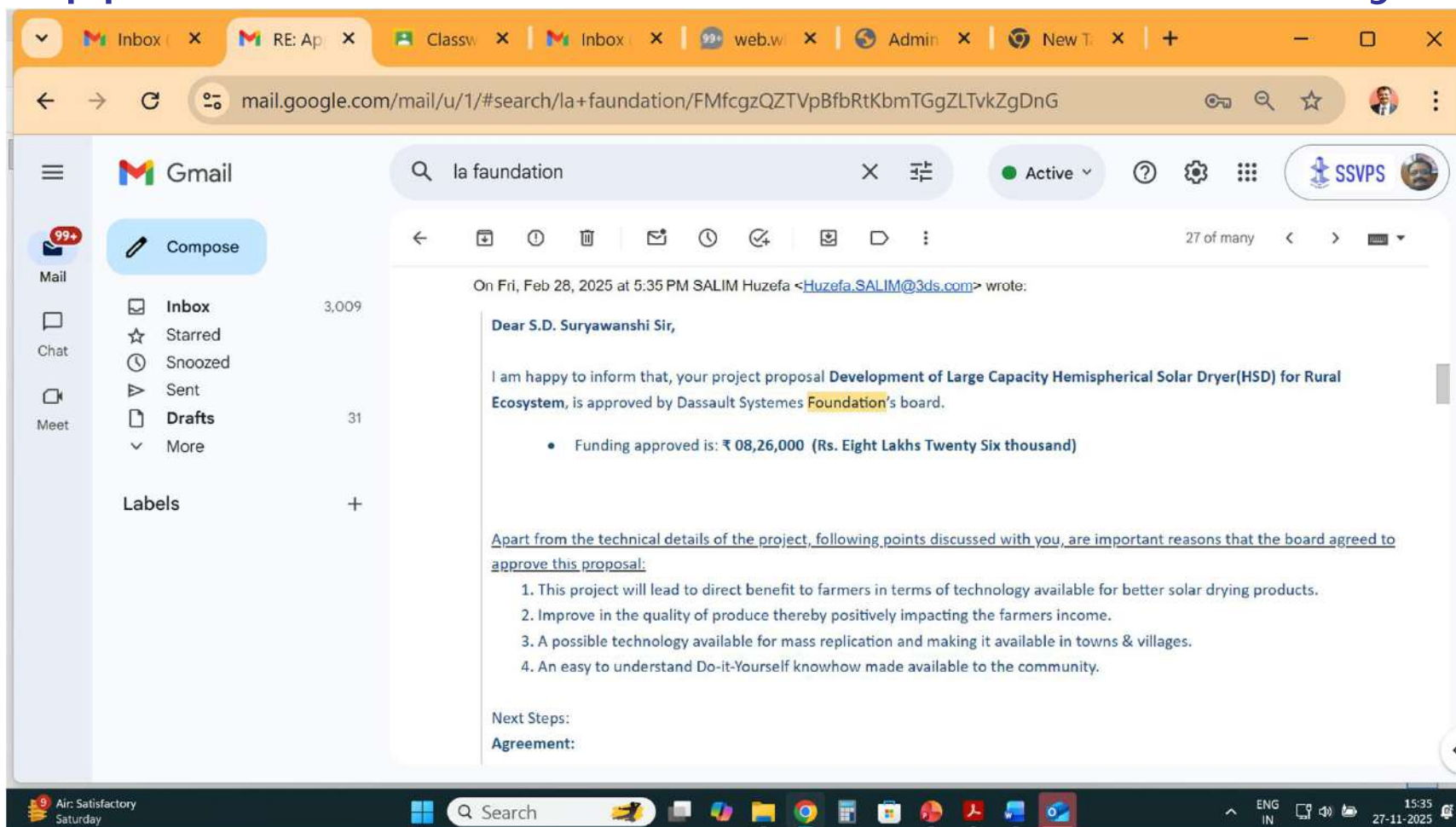

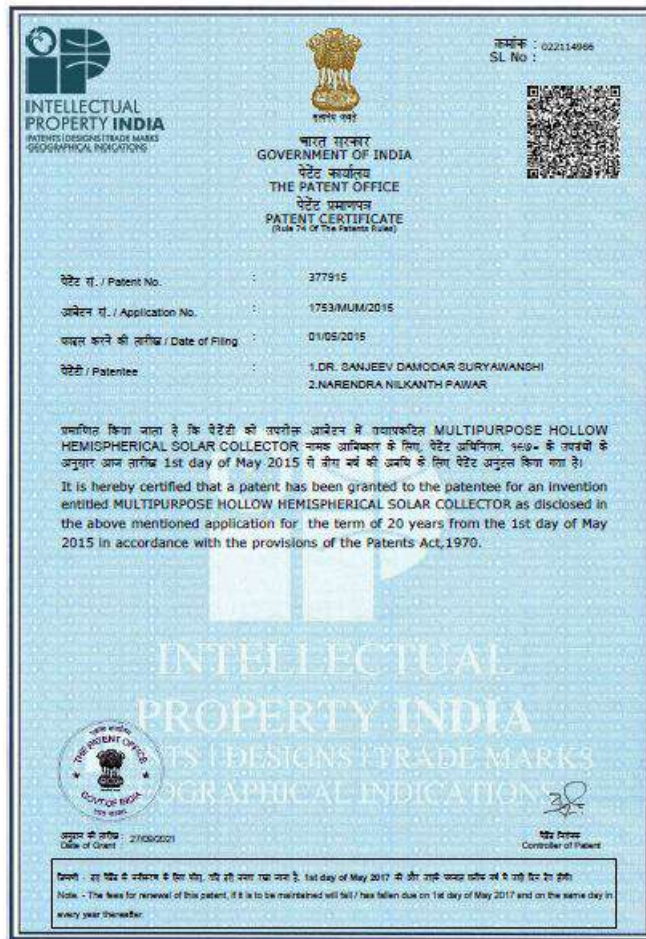

Solar Dryer Cum Disinfector

5/13/2026

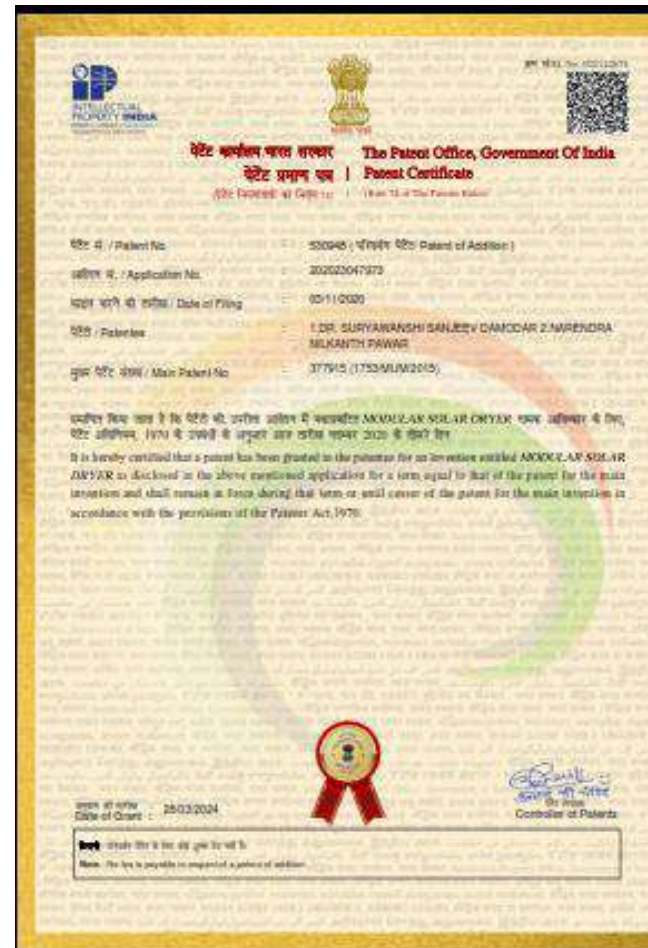

Certificate of Modular Solar Dryer

Every watt is precious

61

US	202023047973 18/251,584	WO2022/097170 A1	Modular Solar Dryer
Indonesiya	PCT/IN2021/051048	P00202304299	Modular Solar Dryer
Vietnam	PCT/IN2021/051048	WO 2022/097170	Modular Solar Dryer
Malesiya	PCT/IN2021/051048	PI2023002688	Modular Solar Dryer

1. [Dhule Tv News](#)- 4<sup>th</sup> June 2025
2. [Jai Maharashtra News](#) - 4<sup>th</sup> June 2025
3. [Aawaj Tv News](#) - 4<sup>th</sup> June 2025
4. [C News \(Hindi\)](#) - 4<sup>th</sup> June 2025
5. [GS-9 News](#) - 4<sup>th</sup> June 2025

# Awards

1. **First prize:** Sustainable Ventilation
2. **Second Prize:** Modular Solar Dryer cum Disinfector and
3. **Third Prize:** Hemispherical Solar Water Heater

Overall prizes of **Rs 1 lakh** in the Innovation Pavilion at the **MET + HMT 2024 conference**, Mumbai

4. AVISHKAR 2019 Award in Doctor Babasaheb Ambedkar Technological University, Lonere, Maharashtra
5. Presented in

- Compose
- Inbox 3,009
- Starred
- Snoozed
- Sent
- Drafts 31
- More

In this context, we are selecting projects which are supported by La Fondation Dassault Systemes and which are aligned with above mentioned objectives and also identify such projects which have potential to be part of the RSVC program. Through this program, the inspirational work done by you and your team will contribute to our national mission of "Developed Villages for Developed India".

We feel following products / technologies developed by you have potential to be deployed at various such RSVCs across India:

Project ID	Technology / Product Title	Lead Professor
IN-2024-3-06	Dome shaped solar dryer for 1 tonne capacity and improved efficiency	Prof. (Dr.) Sanjeev Suryawanshi
IN-2023-2-32	Low cost sustainable ventilation system for thermal comfort in buildings- suitable for building in rural areas	Prof. (Dr.) Sanjeev Suryawanshi

PSA office has set-up a committee of Technical Experts to review, assess and certify such technologies / products. Such certified technologies will then be made available to RSVC centers through e-Commerce platform.

As a first step towards it, we request you to fill-in details about your product / technology (listed above) in the on-line Jot Form (<https://form.jotform.com/251700828644054>)

- Please fill separate forms for each product / technology, developed by you / your institute; and you believe it meets the



# Thank You



*The woods are lovely, dark 'n deep...*